

MC300E

JANOME

TABLE OF CONTENTS

MECHANICAL ADJUSTMENT

Changing External Parts (1) Face Cover	1
Changing External Parts (2) Belt Cover	2
Changing External Parts (3) Base Cover	3
Changing External Parts (4) Bed Cover/ Base Lid (2)	4
Changing External Parts (5) Base Unit	5
Changing External Parts (6) Front Cover	6
Changing External Parts (7) Rear Cover	7
Adjusting Needle Drop Position	8
Adjusting Hook Timing	9
Adjusting Needle Bar Height	10
Adjusting Clearance between Needle and Hook	11
Adjusting Backlash between Hook Drive Gear and Lower Shaft Gear	12
Adjusting Upper Shaft Shield Plate Position	13
Adjusting Needle Thread Tension	14
Adjusting Tension Release Mechanism	15
Changing Thread Tension Unit	16
Replacing Threader Plate and Adjustment	17
Adjusting Height of Embroidery Foot P	18

ADJUSTMENT FOR ELECTRICAL COMPONENTS

Connector Connection Diagram	19
Replacing Printed Circuit Board	20
Replacing Touch Panel	21
Replacing Printed Circuit Board F	22
Adjusting Solenoid	23
Replacing DC Motor and Motor Belt Tension Adjustment	24
Replacing Carriage Plate (Unit)	25
Adjusting X and Y Sensors	26
Adjusting X and Y Sensors (Instant Adjustment)	27
Adjusting X Motor Gear	28
Replacing Switching Power Supply	29

Changing External Parts (1) Face Cover

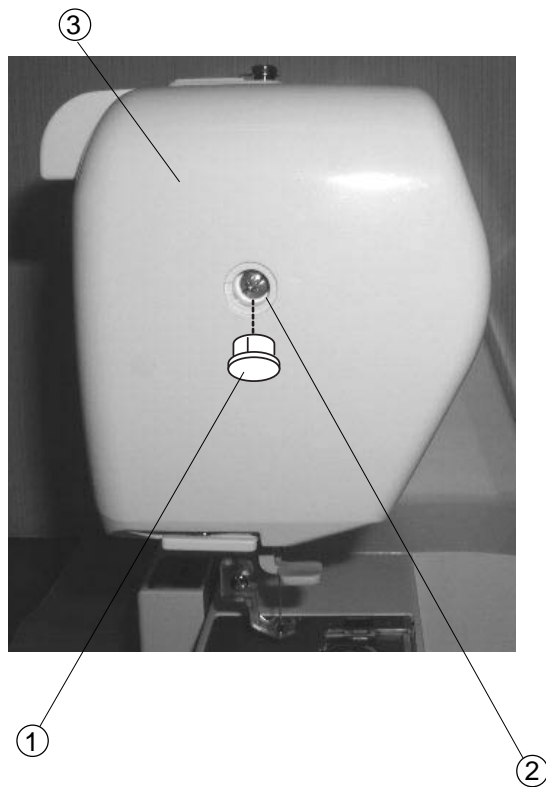

Replacing the face cover

To remove:

1. Remove the Cap (1) and Screw (2) and remove the Face Cover (3) .

- (1) Cap
- (2) Screw
- (3) Face cover

To attach:

2. Attach the Face Cover (3) and tighten Screw (2) , then attach the Cap (1) .

Changing External Parts (2) Belt Cover

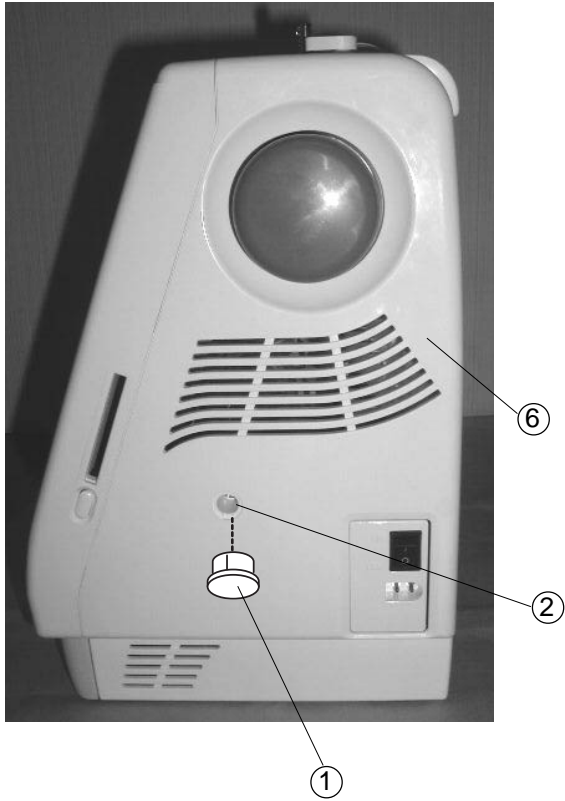

Replacing the belt cover

To remove:

1. Remove the Cap (1) and Screw (A) (2) .
2. Loosen Screw (B) (3) .
3. Lay the machine down on its back and remove Screws C (4) and D (5) , then remove the Belt cover (6) .

- ① Cap
- ② Screw (A)
- ③ Screw (B)
- ④ Screw (C)
- ⑤ Screw (D)
- ⑥ Belt cover

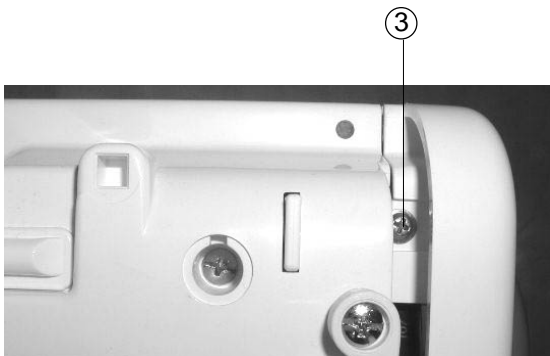

To attach:

4. Attach the Belt Cover with Screws (A - D) (2) - (5) .
5. Attach the Cap (1) .

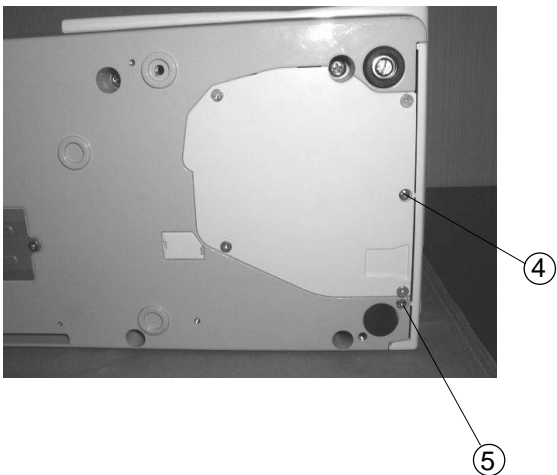

Changing External Parts (3) Base Cover

Replacing the base cover

To remove:

- 1 Remove Screws ① (4 pieces) to remove the base cover ②.

- ① Screw
- ② Base cover

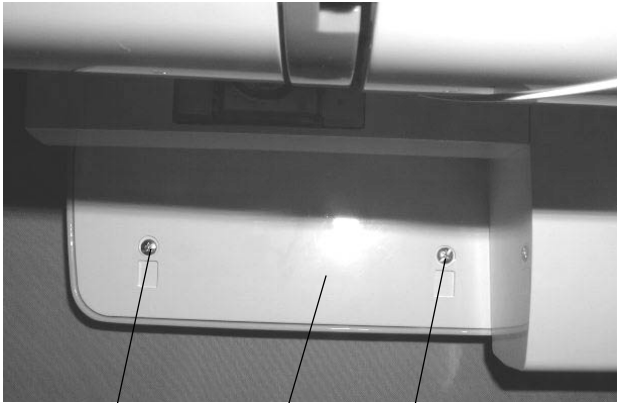

①

②

①



①

①

To attach:

- 2 Follow the above procedure in reverse.

Changing External Parts (4) Bed Cover / Base Lid (2)

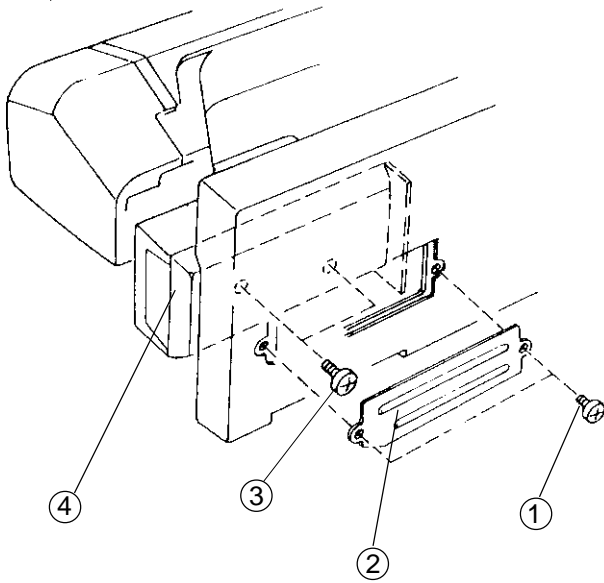

Replacing the bed cover

To remove:

- 1 Remove the base cover.
- 2 Remove Screws (A) ① (2 pcs.), and remove the Base lid (1) ② .
- 3 Remove Screws (B) ③ (2 pcs.), and remove the Bed cover ④ .

- ① Screw (A)
- ② Base lid (1)
- ③ Screw (B)
- ④ Bed cover

To attach:

- 4 Follow the above procedure in reverse.

Replacing the base lid (2)

To remove:

- 1 Remove Screws ① (4 pieces), and remove the Base lid (2) ② .

- ① Screw
- ② Base lid (2)

To attach:

- 2 Follow the above procedure in reverse.

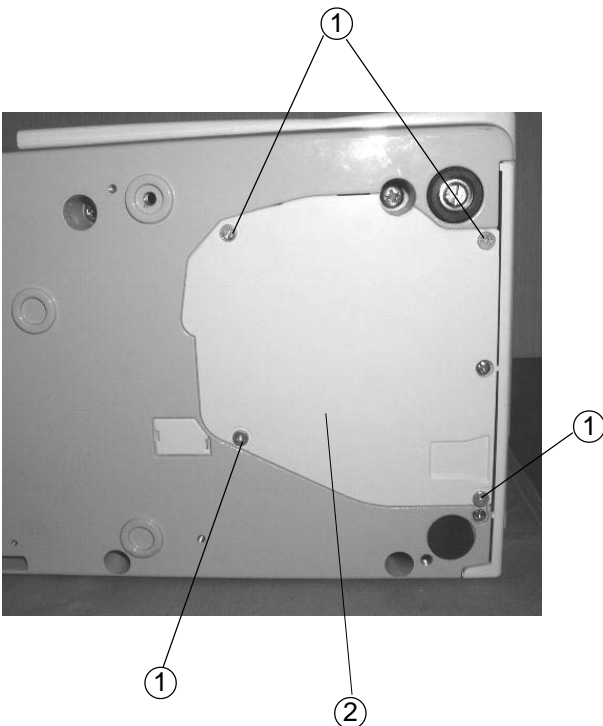

Changing External Parts (5) Base Unit

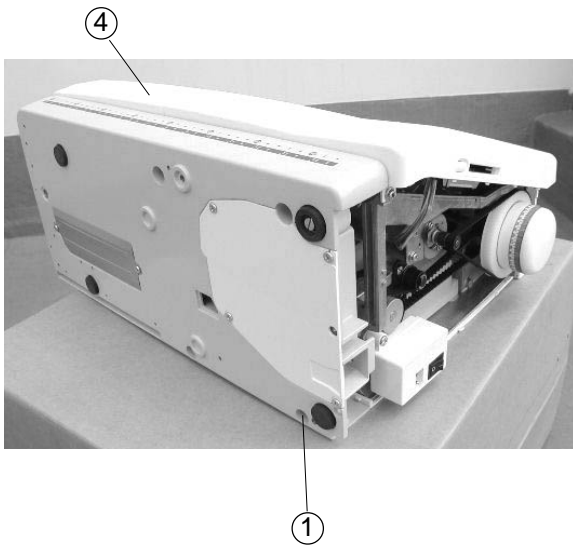
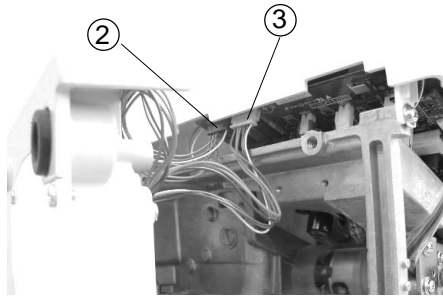
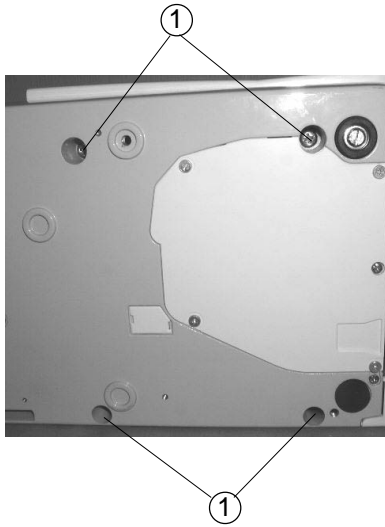

Base

To remove:

- 1 Remove the Belt cover. (See page 2)
- 2 Remove Screws (A) ① (4 pcs.), and remove the base unit .
- 3 Disconnect the X Motor ② and Y Motor ③ connectors from the printed circuit board (A).

- ① Screws (A)
- ② X-motor connector (Blue)
- ③ Y- motor connector (White)
- ④ Extension table (Accessory)

To attach:

- 4 Connect the X, Y - Motor Connectors ②, ③ to the printed circuit board (A).
- 5 Insert the X, Y - Motor cords between the printed circuit board (A) and Arm.
Make sure that the cords should not be caught between the arm and base unit when attaching it, then tighten Screws ① (4 pieces) temporarily.
- 6 Attach the Extension (Accessory) table ④ .
- 7 Tighten Screws (A) ① while aligning the extension table, base unit and free Arm.
- 8 Attach the belt cover.

Changing External Parts (6) Front Cover

Front cover

To remove:

- 1 Remove the face cover, belt cover, base cover and bed cover. (See page 1 - 4).
- 2 Remove Screw (A) ① and remove the Arm thread guide (lower) ② .
- 3 Remove Screw (B) ③ .
- 4 Loosen Screws (C) ④ , (D) ⑤ .
- 5 Disconnect each connector and remove the front cover.

Note: Unlock the Hooks before removing the Front cover.

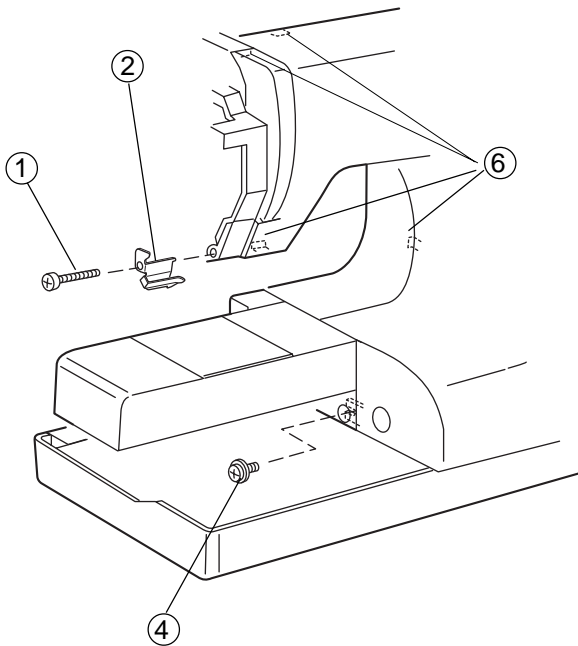

- ① Screw (A)
- ② Arm thread guide (Lower)
- ③ Screw (B)
- ④ Screw (C)
- ⑤ Screw (D)
- ⑥ Hooks (4 spots)

To attach:

- 6 Follow the above procedure in reverse.

Note: See page 21 (Diagram) for "Connectors Connection".

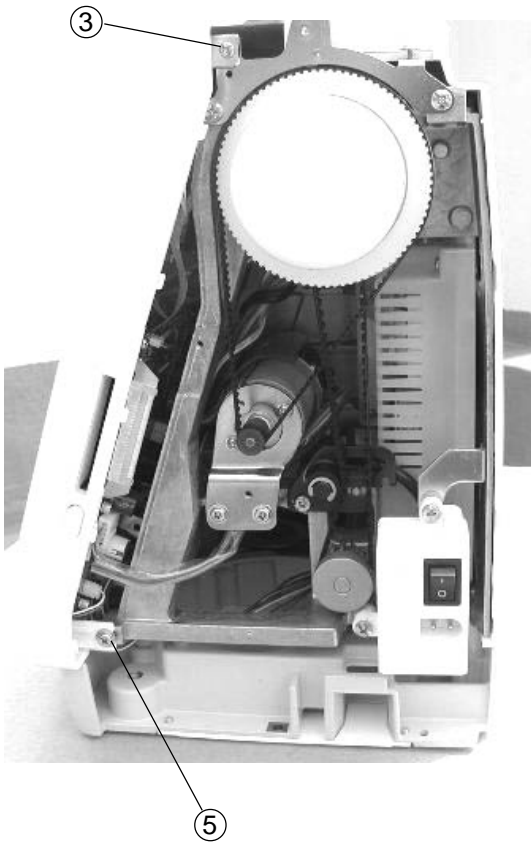

Changing External Parts (7) Rear Cover

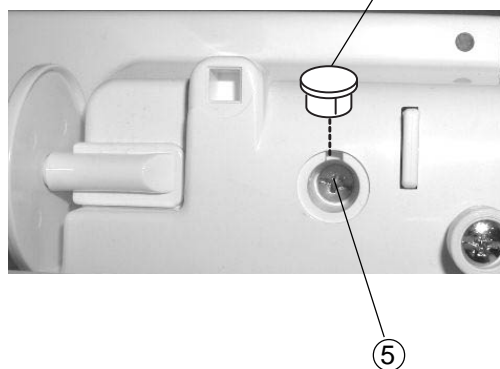
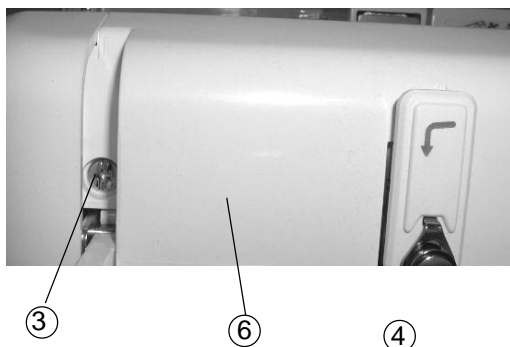
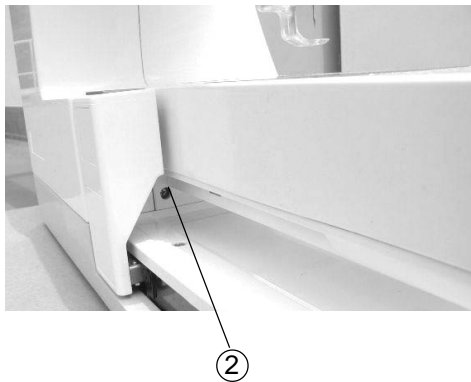
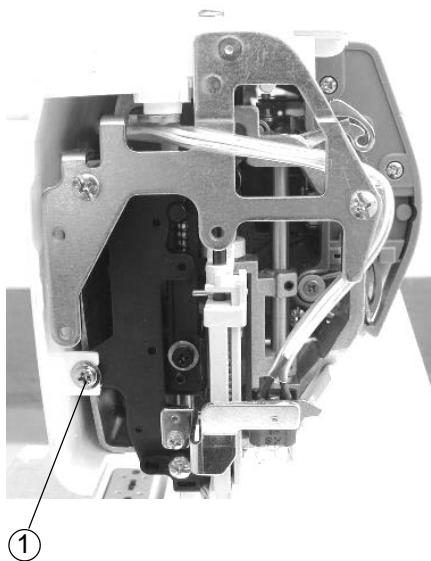

Rear cover

To remove:

- 1 Remove the face cover and belt cover.
- 2 Loosen Screws (A) ①, and (B) ②.
- 3 Raise the handle and remove Screw (C) ③, and Cap ④, then remove Screw (D) ⑤.
Remove the Rear cover ⑥.

- ① Screw (A)
- ② Screw (B)
- ③ Screw (C)
- ④ Cap
- ⑤ Screw (D)
- ⑥ Rear cover

To attach:

- 3 Follow the above procedure in reverse.

Adjusting Needle Drop Position

The needle should be positioned in the center of needle plate hole.

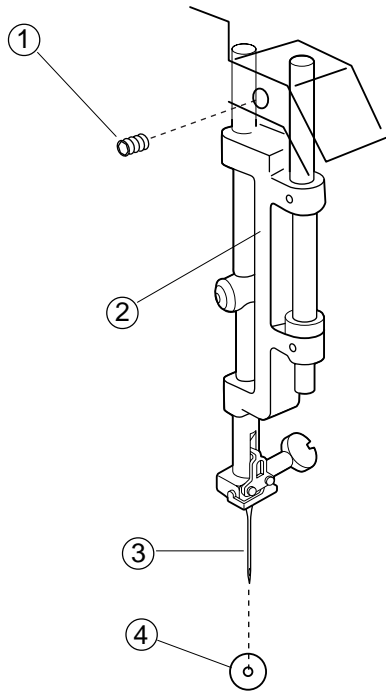

- 1 Lower the Needle ③ to its lowest position by turning the handwheel.
- 2 Remove the face cover and loosen Screw ① , move the Needle bar supporter ② to the right or left until the needle ③ comes to the center of the Needle plate hole ④ .
- 3 Tighten the Screw ① .
- 4 Attach the face cover.

- ① Screw
- ② Needle bar supporter
- ③ Needle
- ④ Needle plate hole

Adjusting Hook Timing

The amount of ascending travel of the needle bar from its lowest position to the position where the tip of the rotary hook meets the right side of the needle should be 3.1 to 3.7 mm.

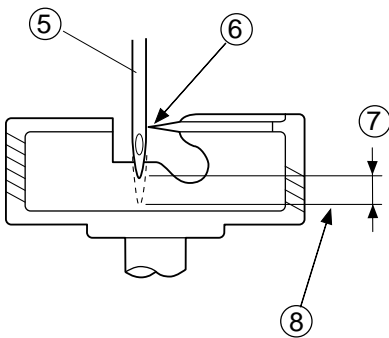
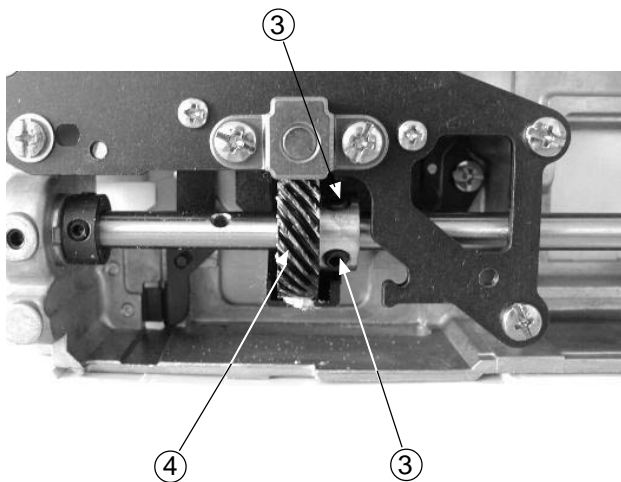
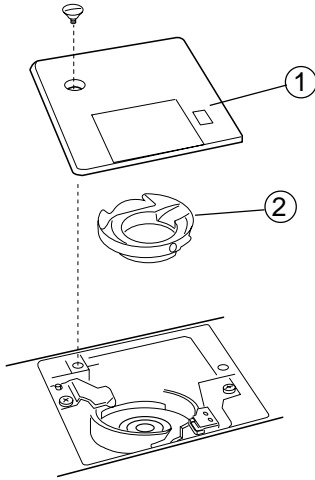

- 1 Remove the belt cover, bed cover, base cover, base lid (1) and base lid (2).
- 2 Remove the presser foot, Needle plate (1) and Bobbin holder (2).
- 3 Lower the needle bar to its lowest position by turning the handwheel toward you.
- 4 Raise the needle bar further 3.4 mm (8) from the lowest position.
- 5 Loosen the Screws (3) of lower shaft gear, turn the Lower shaft gear (4) until the Tip of rotary hook (6) meets with the right side of the Needle (5). Tighten Screws (2 pieces) (3) of the lower shaft gear.
- 6 Attach the Bobbin holder (2), Needle plate (1) and presser foot.
- 7 Attach the base lid (2), base lid (1), base cover, bed cover and belt cover.

- (1) Needle plate
- (2) Bobbin holder
- (3) Screw
- (4) Lower shaft gear
- (5) Needle #14
- (6) Align the tip of rotary hook with the right side of the needle.
- (7) 3.1 to 3.7 mm
- (8) Lowest position

Adjusting Needle Bar Height

The standard distance between the upper edge of the needle eye and the tip of the rotary hook should be in the range of 1.6 - 2.0 mm when the rotary hook meets the right side of the needle in ascending travel of needle from its lowest position.

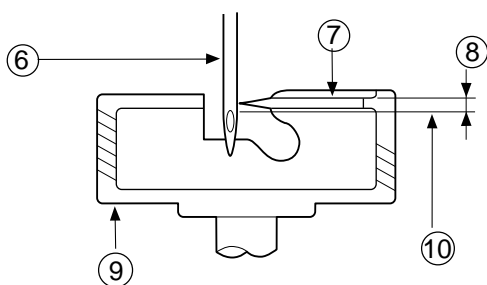
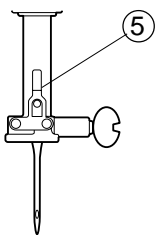
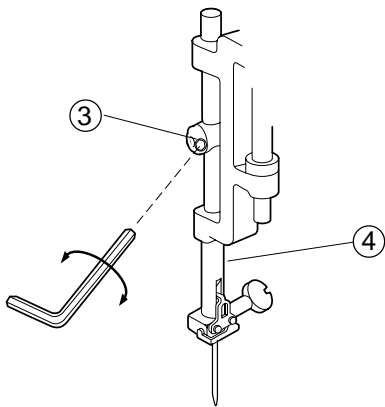
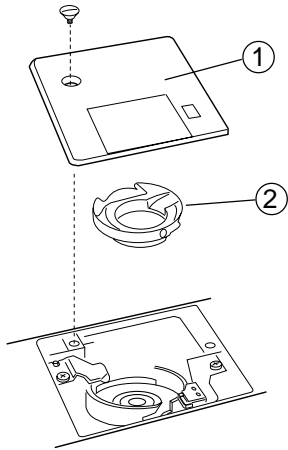

- 1 Remove the presser foot, Needle plate ① and Bobbin holder ② .
- 2 Remove the face cover.
- 3 Turn the handwheel to raise the needle bar from the lowest position until the tip of the rotary hook meets with the right side of the needle ⑦ .
- 4 Loosen Screw ③ .
- 5 Move the Needle bar ④ up or down to adjust the needle bar height.
- 6 Tighten the Screw ③ . Be sure that the groove ⑤ on the needle bar is facing right in the front.
- 7 Attach the Bobbin holder ② , Needle plate ① and presser foot.
- 8 Attach the face cover.

- ① Needle plate
- ② Bobbin holder
- ③ Screw
- ④ Needle bar
- ⑤ Groove
- ⑥ Needle # 14
- ⑦ Surface of hook race
- ⑧ 1.6 - 2.0 mm
- ⑨ Rotary hook race
- ⑩ Top of needle eye

Adjusting Clearance between Needle and Hook

The clearance between needle and rotary hook should be **-0.10 to + 0.05 mm**.

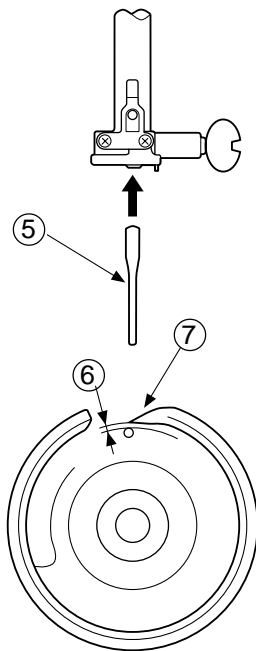
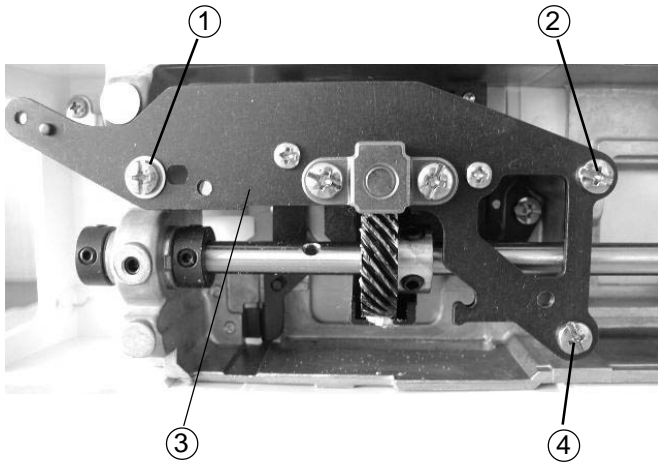

- 1 Remove the needle plate, bobbin holder, base cover and bed cover (See page 3 - 4).
Replace the needle with the Test pin (5).
- 2 Loosen Screws (A) (1), (B) (4), (C) (2) and tighten Screw (C) (2) temporarily.
- 3 Turn the handwheel to bring the tip of the rotary hook behind the test pin.
Adjust the clearance between the Test pin (5) and the Tip of rotary hook (7) to - 0.10 to + 0.05 mm (6) by moving the Rotary hook set plate (3) up or down.
- 4 Tighten the Screws (A) (1), (B) (4), (C) (2) firmly.
- 5 Check the rotary hook driver gear and the lower shaft gear backlash.
If gears mesh or engage tightly or loosely, check "Adjusting Backlash between Hook Drive Gear and Lower Shaft Gear". (See page 12)
- 6 Reattach the bed cover, base cover, base lid, bobbin holder, needle plate and needle.

- (1) Screw (A)
- (2) Screw (C)
- (3) Rotary hook set plate
- (4) Screw (B)
- (5) Test pin
- (6) - 0.10 to +0.05 mm
- (7) Tip of rotary hook

Adjusting Backlash between Hook Drive Gear and Lower Shaft Gear

The rotary play of the hook should be 0.8 mm or less.

Adjust the backlash after the adjustment of the clearance between needle and rotary hook.

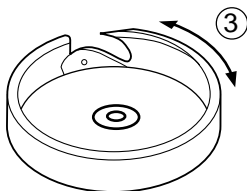
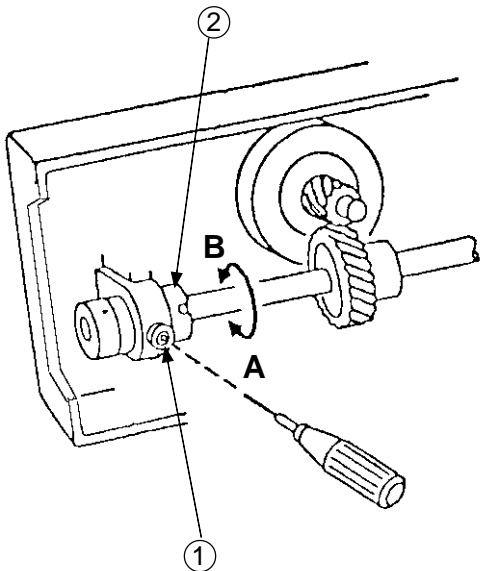

To check:

- 1 Turn the power switch "OFF".
- 2 Remove the base cover, bed cover, needle plate and bobbin holder.
- 3 Jog the hook race with fingers to check the rotary play. "If the play is larger than 0.8 mm or the gears do not turn smoothly, adjust the backlash as follows".

Adjustment procedure:

- 1 Remove the bed cover (See page 4) and loosen the Screw ① .
- 2 Turn the Lower shaft bushing ② (Eccentric), in the direction "B" when the play at shuttle hook tip is too small.
- 3 Turn the Lower shaft bushing ② (Eccentric), in the direction "A" when the play at shuttle hook is too large.
- 4 Tighten Screw ① securely after adjustment.

- ① Screw
- ② Lower shaft bushing
- ③ The rotary hook play should be 0.8 mm or less.

Adjusting Upper Shaft Shield Plate Position

The standard height of needle stop position should be 14.2 mm above the needle plate surface when the machine is topped.

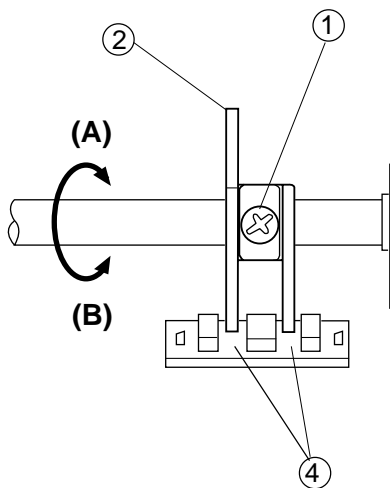
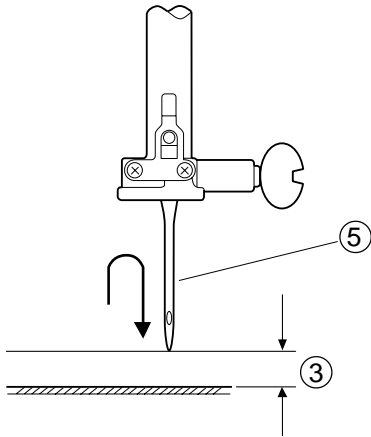

- 1 Remove the front cover unit. (See page 6)
- 2 Turn the power switch "ON" and press Start / Stop button twice.
Stop the machine with the needle in the up position.
- 3 (A) If the needle stops higher than 14.2 mm, loosen Screw ① and turn the Upper shaft shield plate ② in the direction of (A).
(B) If the needle stops lower than 14.2 mm ③ , loosen Screw ① and turn the Upper shaft shield plate ② in the direction of (B).
- 4 Place the right side of the Upper shaft shield plate ② in the center of the slit of the Upper shaft sensor ④ and tighten Setcrew ① .
- 5 Press the Start/Stop button twice to check the height of the needle stop position, then attach the front cover.

- ① Screw
- ② Upper shaft shield plate
- ③ 14.2 mm
- ④ Upper shaft sensor
- ⑤ Needle #11

Adjusting Needle Thread Tension

The standard upper thread tension should be 51 to 59 grams when the tension dial is set at “3”, measured with a #50 polyester thread being pulled at approximately 110 mm/sec. in the direction of arrow.

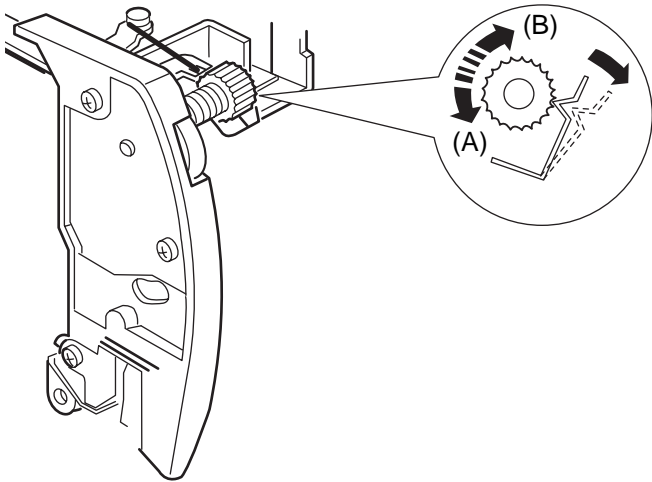

- 1 Set the Thread tension dial at “3”.
- 2 Lower the presser foot.
- 3 Remove the front cover unit and adjust the thread tension.

- (A) If the thread tension is more than 59 g
.....turn the screw in the direction of “B”.
- (B) If the thread tension is less than 51 g
.....turn the screw in the direction of “A”

① Pulling direction: (Pulling speed 110 mm/ Sec.)

- 4 Attach the front cover unit.

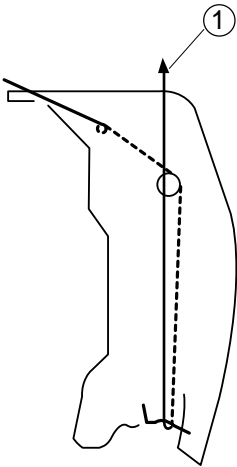

Adjusting Tension Release Mechanism

When the presser foot lifter is raised, the tension release mechanism should work correctly. If not, adjust as follows.

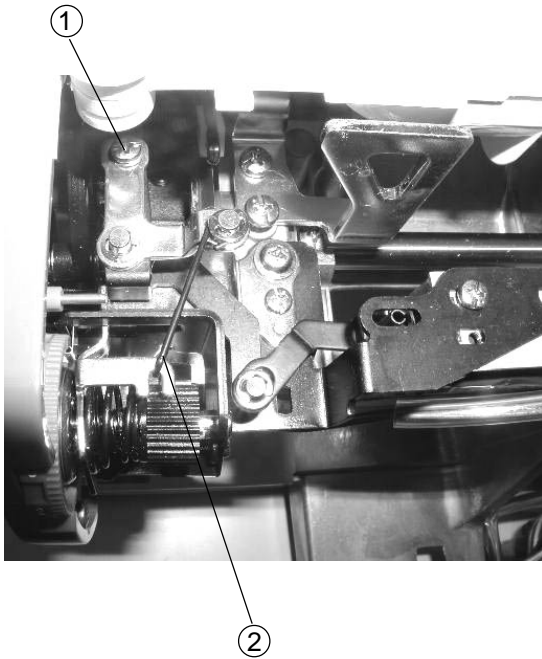

- 1 Remove the front cover unit. (see page 6)
- 2 Lower the presser foot lifter, set the thread tension dial at "9" and loosen the Screw ① .
- 3 Adjust the play between the tension release rod (2) ③ and the Spring holder ④ approximately 0.3 - 0.5 mm and tighten the Screw (A) ① .
- 4 Raise the presser foot lifter, turn the thread tension dial from "9" to "0", make sure the tension disc ⑤ should open 1.0 mm ⑥ .
- 5 Reattach the front cover unit.

- ① Screw
- ② Tension release rod (2)
- ③ Play (0.3 - 0.5 mm)
- ④ Spring holder
- ⑤ Tension disc
- ⑥ Clearance (approximately 1.0 mm)

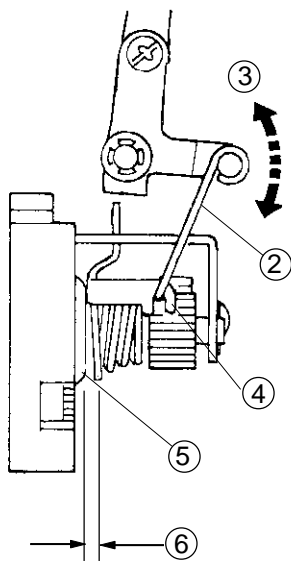

Changing Thread Tension Unit

Replacing the thread tension unit

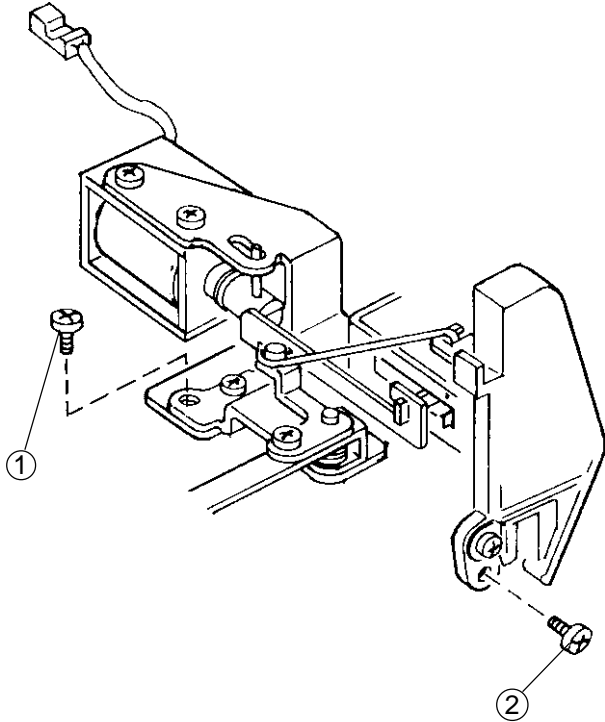

To remove:

- 1 Remove the front cover unit. (See page 6)
- 2 Remove Screws (A) ① , (B) ② , and remove the thread tension unit.

To attach:

- 3 Follow the above procedure in reverse.

Note: After the replacement, adjust "Thread Tension Release Mechanism" and Solenoid.

- ① Screw (A)
- ② Screw (B)

Replacing Threader Plate and Adjustment

If the hook on the threader plate is damaged, replace it as follows.

Fig. 1

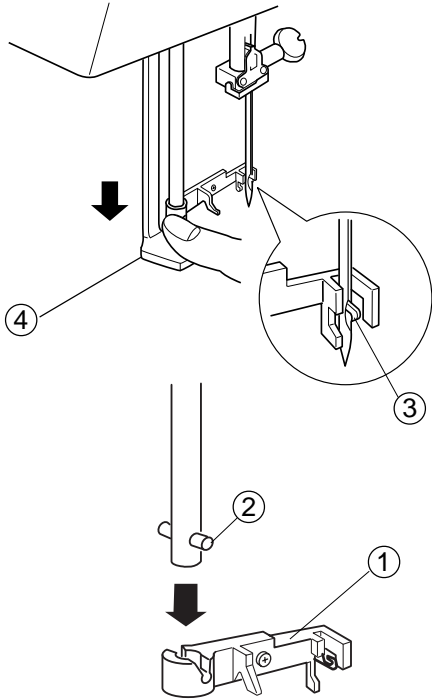

To replace:

- 1 Pry out the Threader plate holder (1) with screwdriver while pushing and holding the Threader knob (4) (See fig.1.).
- 2 Align the groove on the new Threader plate holder (1) with the Pin (2) on the threader shaft. Push the Threader plate holder (1) up until it snaps in place.

- (1) Threader plate holder
- (2) Pin
- (3) Hook
- (4) Threader knob

Fig. 2

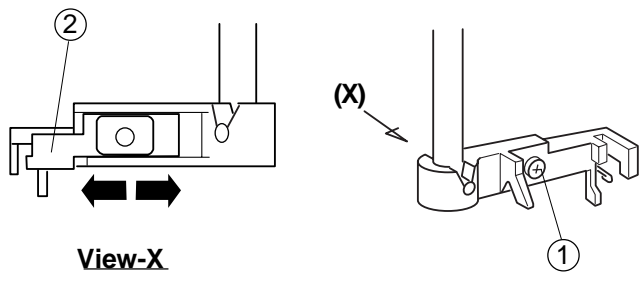

Adjustment procedure:

1. If the threader hook thrusts or hits against either left or right edge of the needle eye: Loosen Screw (A) (1) and adjust the position of the Threader plate (2). (See fig. 2).
2. If the threader hook thrusts against either top or bottom edge of the needle eye, or misses the needle eye:

Remove the face cover and loosen Screw (B) (3). Move the Threader position adjusting holder (4) up or down to adjust the hook position.

Fig. 3

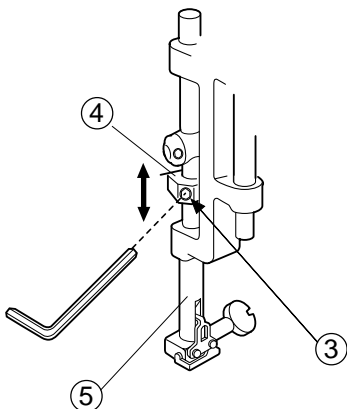

- (1) Screw (A)
- (2) Threader plate
- (3) Screw (B)
- (4) Threader position adjusting holder
- (5) Needle bar

Adjusting Height of Embroidery Foot P

Space between the needle plate and the bottom surface of the Foot (P) should be 1.0 to 1.6 mm, when the needle bar is at its lowest position.

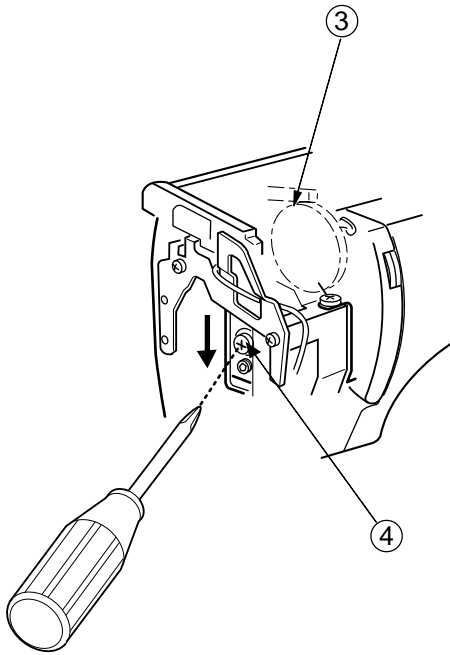

- 1 Remove the front cover unit. (See page 6)
- 2 Lower the needle bar and lower the presser foot lifter.
- 3 Insert the 1.2 mm Thickness gauge (1) between the Embroidery Foot (P) (2) and the needle plate.
- 4 While pressing the Pressure bar actuator (3) down against the upper shaft cam, loosen the Screw (A) (4) and push it down to the direction of arrow, then tighten Screw (A) (4) again.
- 5 Reattach the rear cover.

- ① Thickness gauge
- ② Embroidery foot (P)
- ③ Pressure bar actuator
- ④ Screw (A)
- ⑤ Needle
- ⑥ Needle plate

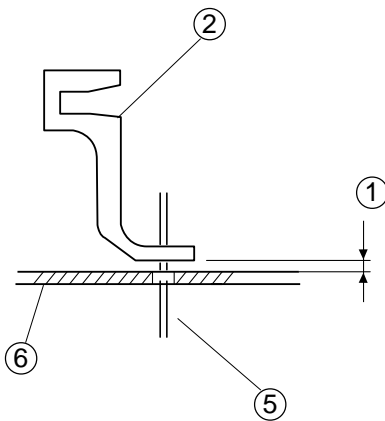

Connector Connection Diagram

Please see the following connector connection diagram for the printed circuit board A.

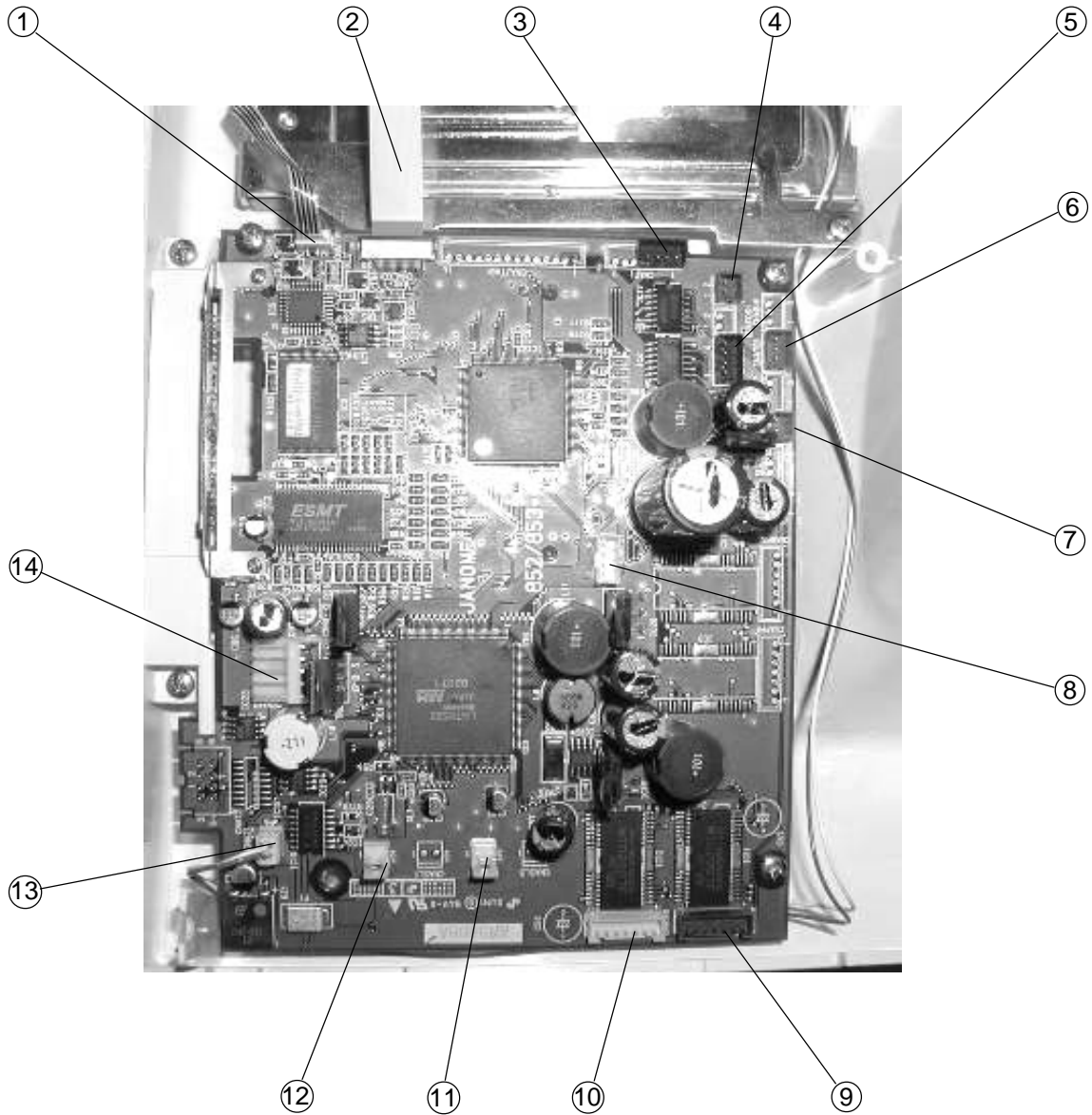

- | | |
|--------------------------------------|---------------------------------------|
| ① Touch panel | ⑧ Switching power supply (White) |
| ② LCD Harness | ⑨ X- Motor (Blue) |
| ③ Printed circuit board F(Black) | ⑩ Y- Motor (White) |
| ④ Bobbin winder sensor (Blue) | ⑪ Solenoid for thread tension (Red) |
| ⑤ Upper shaft sensor (Black) | ⑫ Lamp (White) |
| ⑥ Thread detection sensor (Red) | ⑬ Inverter (White) |
| ⑦ Presser foot lifter sensor (Red) | ⑭ DC Motoe (White) |

Replacing Printed Circuit Board A

To remove:

- 1 Remove the front cover. (See page 6)
- 2 Pull out the connectors of printed circuit board F LCD Harness, Inverter and Touch panel.
- 3 Remove Screws (5 pieces) ① and the Printed circuit board A ② with the Card guide ③.

To attach:

- 4 Follow the above procedure in reverse.

- ① Screws (5 pieces)
- ② Printed circuit board (A)
- ③ Card guide



Replacing Touch Panel

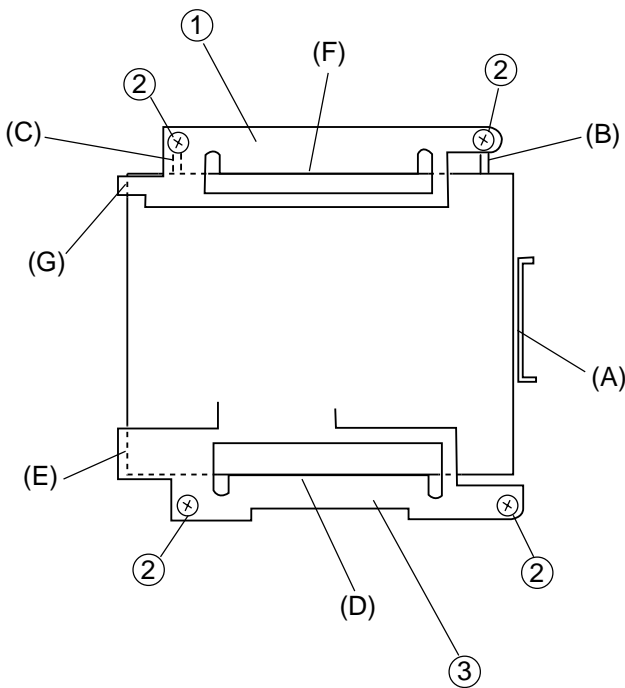

To remove:

- 1 Remove the front cover. (See page 6)
- 2 Pull out the Connectors of printed circuit board F (4) , LCD Harness (5) and Inverter connector (6) and Touch panel connectors (7) .
- 3 Remove Screws (2) (4 pieces) and remove the Touch panel (8) .

To attach:

- 4 Place the Touch panel (8) and press it against the Ribs (A), (B), (C).
Fix the Touch panel (8) with the Fixing plate (bottom) (3) while press it against the Touch panel (8) and tighten screws (2) .
- 5 Place the Fixing plate (top) (1) and secure it with Screws (2) while pressing the Fixing plate (top) (1) against the Touch panel (8) .

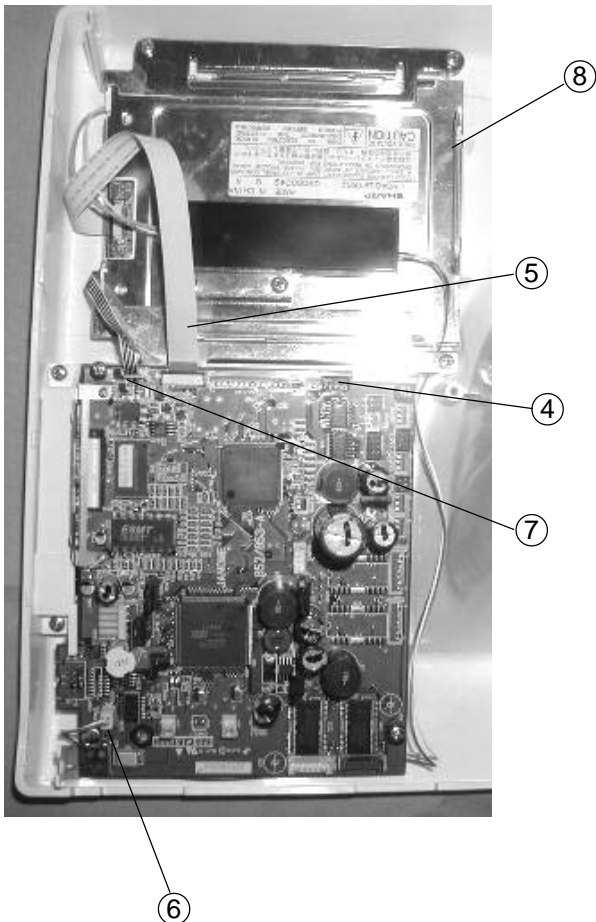

- ① Fixing plate (Top)
- ② Screw
- ③ Fixing plate (Bottom)
- ④ Printed circuit board F
- ⑤ LCD Harness
- ⑥ Inverter connector
- ⑦ Touch panel connector
- ⑧ Touch panel (Rear side)

Replacing Printed Circuit Board F

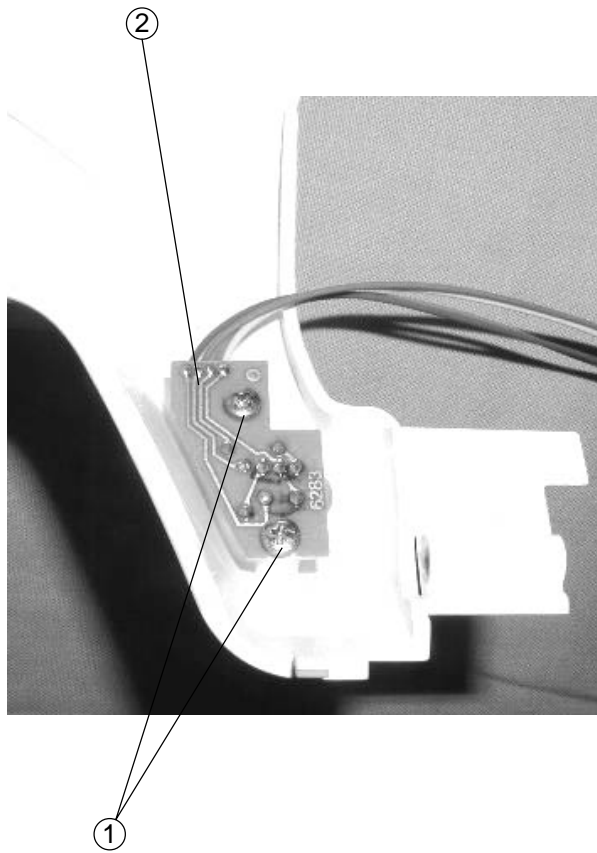

To remove:

- 1 Remove the front cover. (See page 6)
- 2 Pull out the connectors from the printed circuit board A.
- 3 Remove Screws ① (2 pieces) and remove the Printed circuit board F ② .

To attach:

- 4 Follow the above procedure in reverse.

- ① Screws (2 pieces)
- ② Printed circuit board F

Adjusting Solenoid

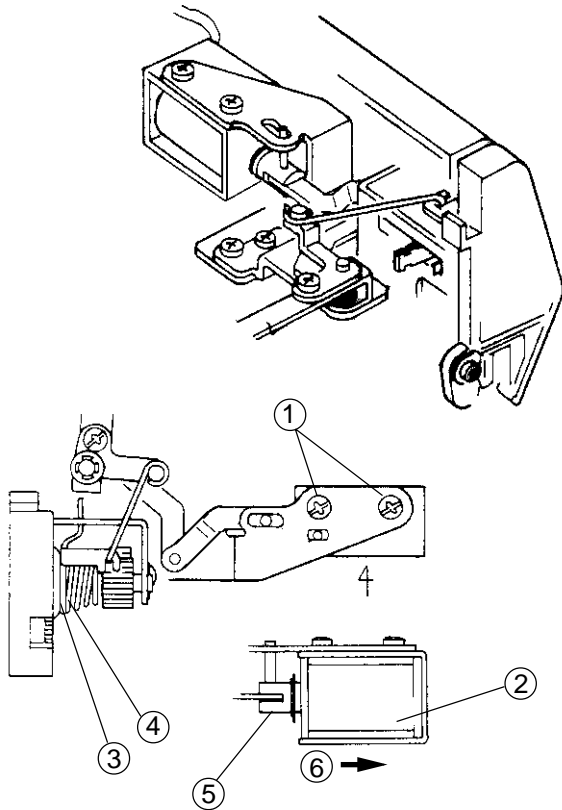

1. Remove the front cover. (See page 6)
2. Loosen Screws ① (2 pieces).
3. Slide the Solenoid ② to the right most position.
- 4 Tighten Screws ① .

- ① Screw (A)
- ② Solenoid
- ③ Tension disc
- ④ Tension disc holder
- ⑤ Plunger
- ⑥ Slide to the right.

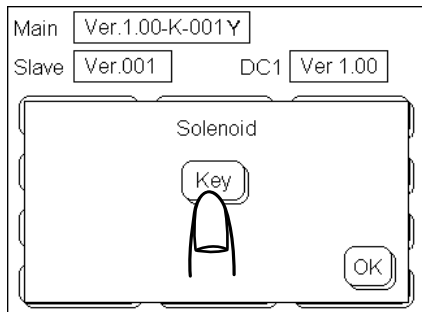
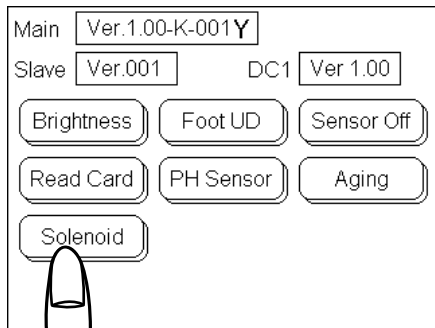

- 5 To check tension release function
 - a. Turn the power switch "ON" while pressing the Start/Stop button. Touch panel indicates the Self Check function keys as shown.
 - c. Press the "Solenoid" key on the touch panel and it will indicate Solenoid "Key".
 - d. Press the Solenoid "Key" several times to check if the Tension disc ③ and Tension disc holder ④ open when the solenoid is activated.
 - e. Press "OK" key.
 - f. Attach the front cover.

Note: Do not touch the Self Check function keys other than the "Solenoid".

Replacing DC Motor and Motor Belt Tension Adjustment

Replacing DC Motor

To remove:

- 1 Remove the belt cover. (See page 2)
- 2 Remove the Motor belt ① .
- 3 Disconnect the Motor connector ② from the printed circuit board A.
- 4 Remove Screws (A) ③ (2 pieces) and replace the motor.

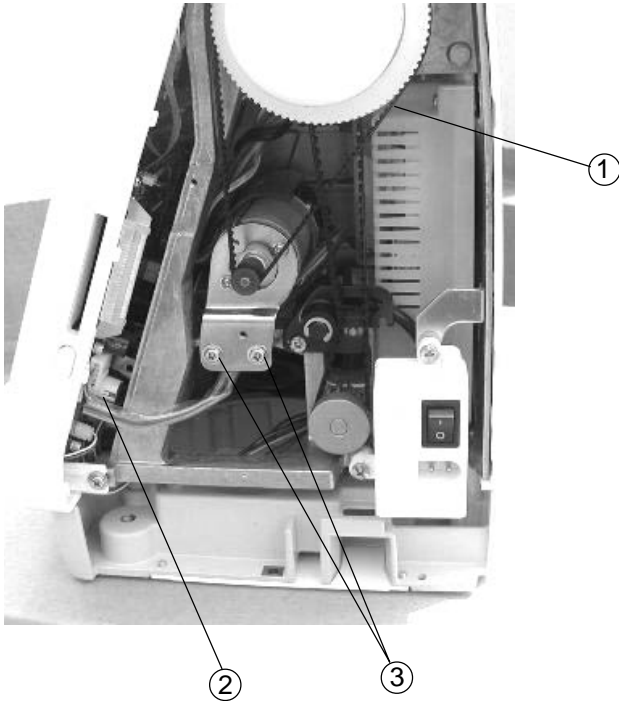

To attach:

- 5 Follow the above procedure in reverse.

Adjusting motor belt tension

1. Tighten Screws ③ (2 pieces) temporarily.
2. Adjust the Belt deflection to about 5.0 mm ⑤ while pressing the middle of the motor belt with your finger with approximately 200 grams ④ of pressure.
- 3 Tighten Screw ③ securely.

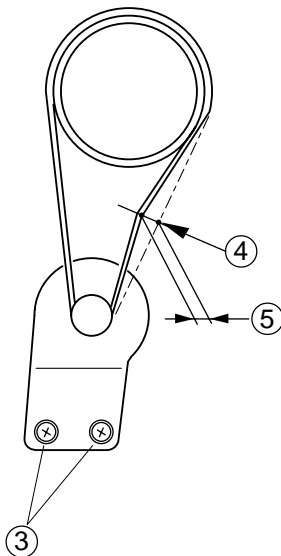

- ① Motor belt
- ② Motor connector
- ③ Screws
- ④ Pressure 200 grams
- ⑤ Deflection 5 mm

Replacing Carriage Plate (Unit)

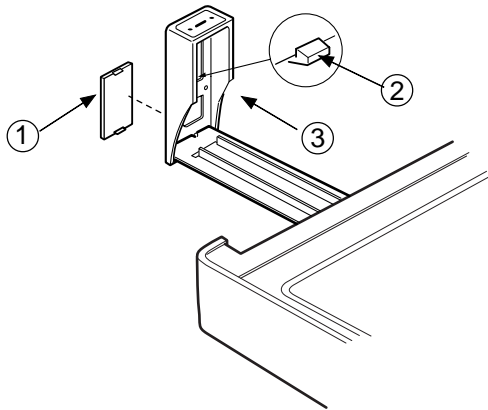

To remove:

- 1 Turn the power switch "ON" and select the pattern No.1.
- 2 Turn the power switch "OFF" and remove the Cover cap ① . (Unlock the hook from the inside.)
- 3 Turn the power switch "ON" to return the carriage to the home position.
- 4 Remove Screws ④ (3 pieces) and remove the carriage plate.

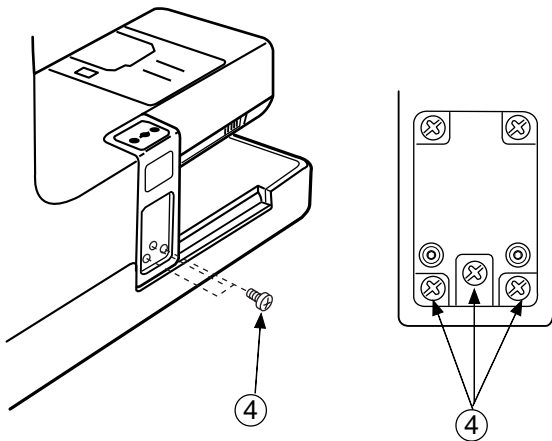

To attach:

- 5 Attach the carriage plate (unit) and tighten screws temporarily.
- 6 Adjust the carriage plate position so that its top surface is parallel and the same level with the bed surface. Tighten the screws securely.
- 7 Attach the cover cap ① .

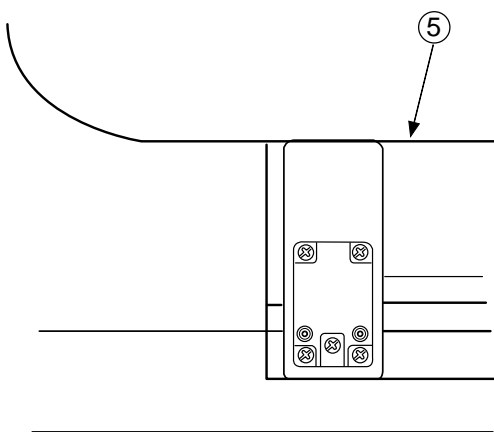

- ① Cover cap
- ② Hook
- ③ Drop plate
- ④ Screws
- ⑤ Arm surface

Adjusting X and Y Sensors

To adjust X and Y sensors:

- 1 Turn the power switch "ON" (The carriage is automatically set at starting position.)
- 2 Turn the power switch "OFF" and then remove the base unit.
- 3 Loosen Screw A ① and move the Y-Sensor fixing plate ③ to adjust the carriage position. Turn the power switch "ON" again to check if the Distance (Y) ② is adjusted to 2.5 mm. Tighten Screw (A) ①.
- 4 Loosen screw B ④ and move the X-shield plate ⑦ to adjust the carriage position (X-1) ⑤ and (X-2) ⑥ . Turn the power switch "ON" again to check if the distance (X-1) ⑤ is adjusted to 69.5 mm and (X-2) ⑥ is adjusted to 2.5 mm.
- 5 Tighten Screw ④ .
6. Attach the base.

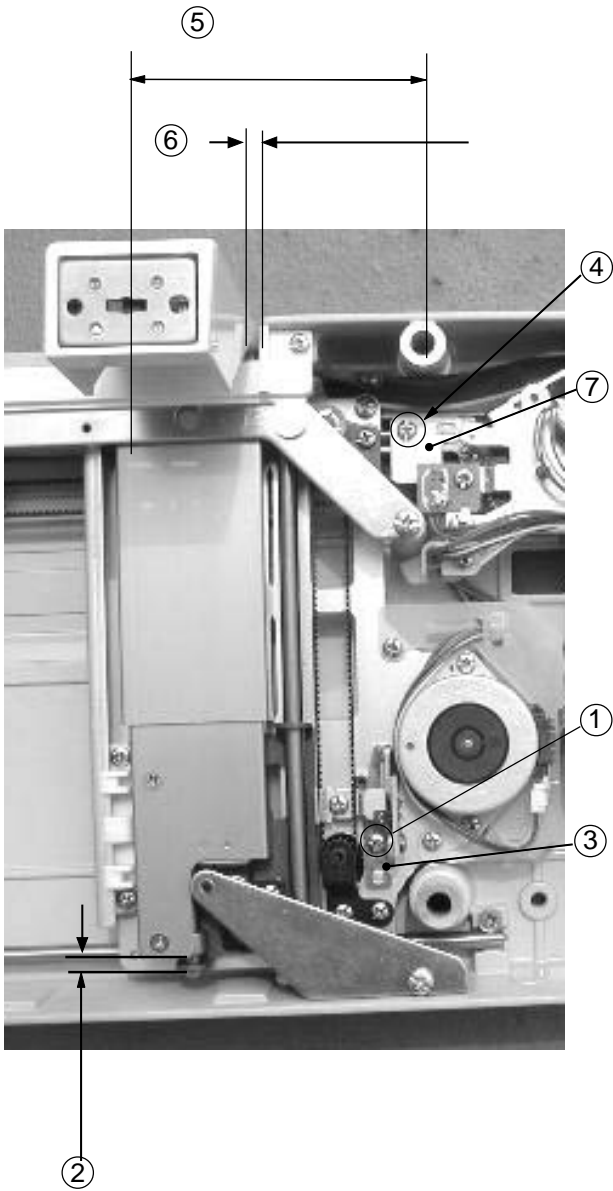

- ① Screw (A)
- ② Y (2.5 mm)
- ③ Y Sensor fixing plate
- ④ Screw (B)
- ⑤ X-1 (69.5 mm)
- ⑥ X-2 (2.5 mm) between the edge of carriage and Base
- ⑦ X shield plate

Adjusting X and Y Sensors (Simple Adjustment)

To adjust X and Y sensor (without removing the base unit):

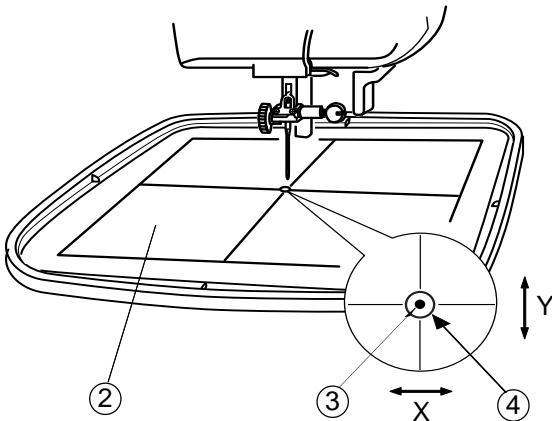

- 1 Remove the base cover.
- 2 Remove the presser foot holder and place the fabric on the Embroidery hoop (A).
Attach the Embroidery hoop (A) on the carriage.
(Place the Template (2) on the Embroidery hoop as shown.)
- 3 Turn the power switch "ON" and select the pattern No.1 on the touch panel.
- 4 Check that the Needle (3) goes into the Hole (4) in the Template (2) .

- 5 Turn the power switch "OFF".

- 6 If the needle drop position is slightly out of position in the Y-direction, loosen the screw (A) (1) and move the Y-sensor fixing plate (8) to adjust.
If the needle drop position is slightly out of position in the X direction, loosen Screw (B) (5) through the hole of the Sheet cover fixing plate hole (7) , and move the X shield plate (6) to adjust.

- 7 Turn the power switch "ON".
Select the pattern No.1 on the touch panel, then check if the needle goes into the center of the hole in the Template (4) .

- 8 Return the carriage to the stored position, then turn the power switch "OFF".

- 9 Remove the Template (2) and Embroidery hoop then install the base cover.

- ① Screw (A)
- ② Template
- ③ Needle
- ④ Hole in the template
- ⑤ Screw (B)
- ⑥ X-shield plate
- ⑦ Hole of the sheet cover fixing plate
- ⑧ Y-Sensor fixing plate
- ⑨ Y-direction
- ⑩ X-direction

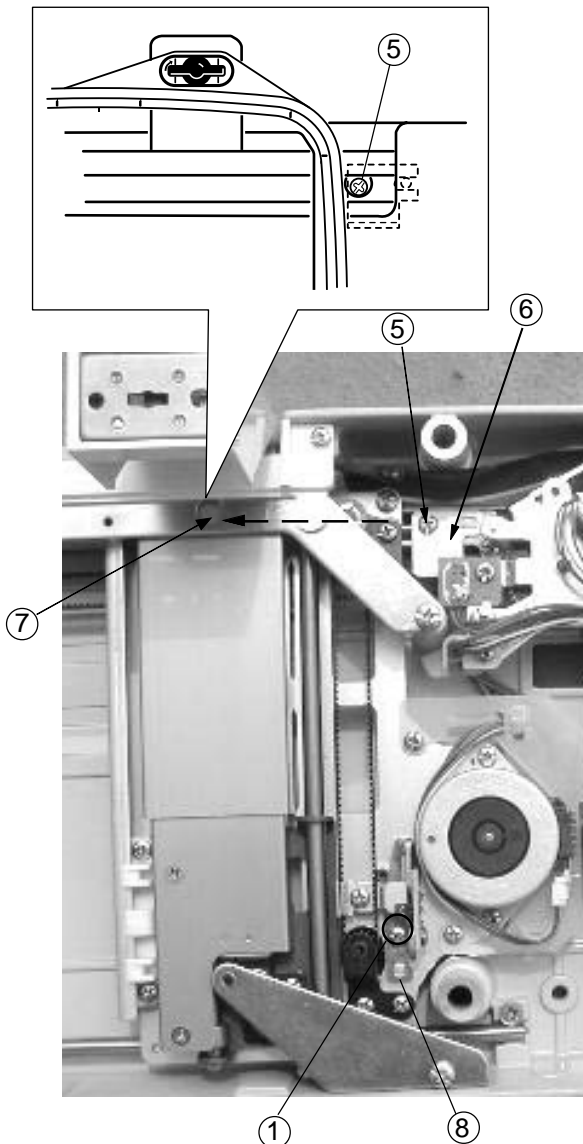

Adjusting X Motor Gear

If the machine is noisy when sewing an embroidery design, adjust the X-Motor as follows.

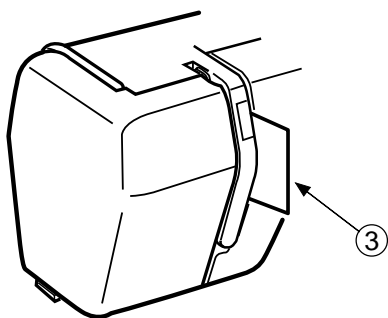

To remove:

- 1 Remove the base unit (See page 5).
- 2 Remove the presser foot.
- 3 Remove Screw (A) ① and remove the Nylon clip ② from the cords.

Adjustment procedure:

- 4 Connect the X ,Y motor connectors to printed circuit board A.
- 5 Turn the power switch "ON" and select the 3 large "A"s of Gothic of the monogramming.
- 6 Lower the presser bar after the carriage moves to the sewing position.
- 7 To unblock the needle thread sensor, insert a piece of paper ③ into the channel as shown.
- 8 Run the machine and loosen Screws (B) ④ (2 pieces). While the carriage is moving in the direction of arrows ⑥ , adjust the X-Motor position where the lowest noise is obtained and tighten Screws (B) ④ firmly.
- 9 Return the carriage to the stored position and turn the power switch "OFF".
- 10 Pull the X ,Y motor connectors out from the printed circuit board A, then tighten screw (A) to place the Nylonclip ② .
- 11 Connect the X, Y motor connectors to the printed circuit board A again.
- 12 Install the base unit.

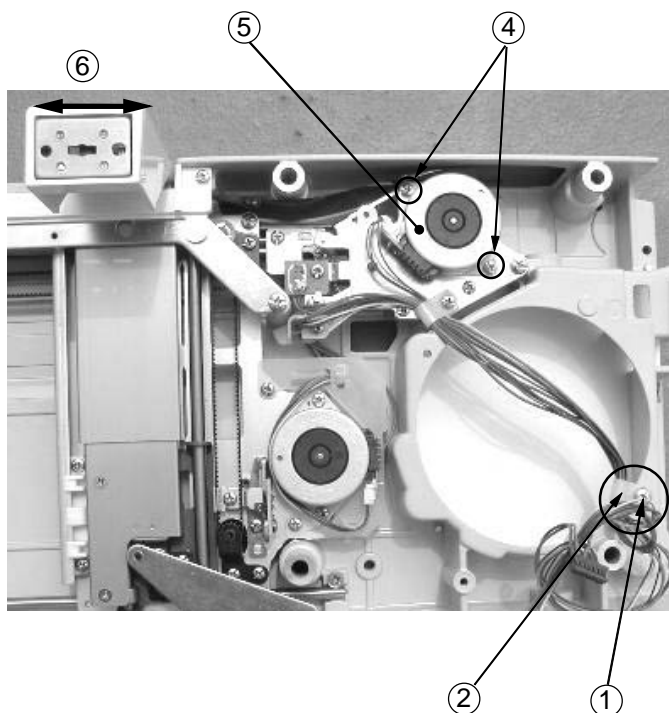

- ① Screw A
- ② Nylon clip
- ③ Insert a piece of paper
- ④ Screw B
- ⑤ X- motor
- ⑥ Carriage moving in lateral direction

Replacing Switching Power Supply

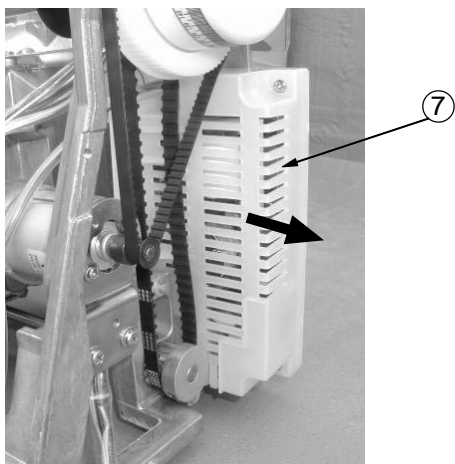
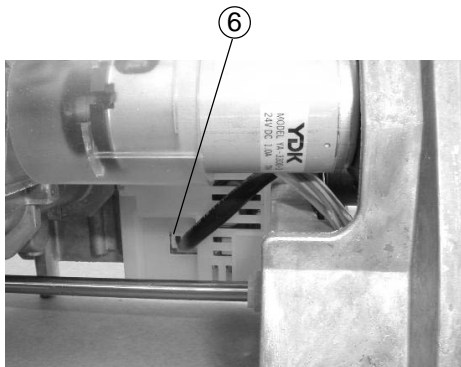
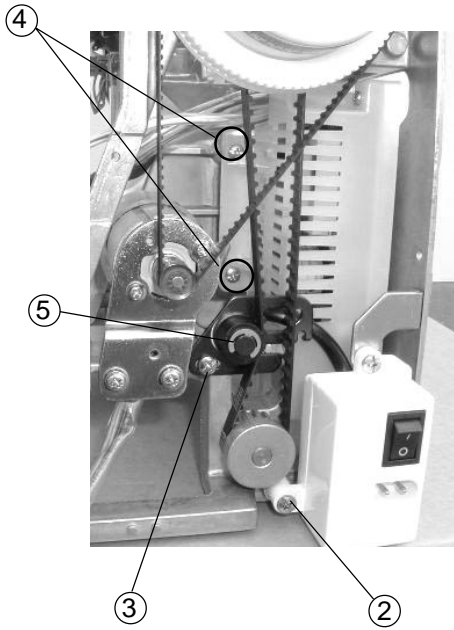
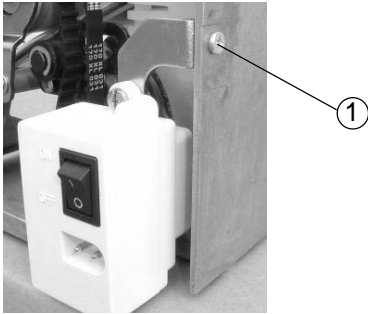

To remove:

- 1 Remove the face cover, belt cover, front cover and rear cover.
- 2 Remove Screws (A) ① , (B) ② and remove the machine socket and fixing plate.
- 3 Pull out the Machine socket unit connector ⑥ .
- 4 Remove Screw (C) ③ and remove the Idler.
- 5 Remove Screws (D) ④ (2 pieces) and take out Switching power supply ⑦ .

To attach:

- 6 Follow the above procedure in reverse.

- ① Screw (A)
- ② Screw (B)
- ③ Screw (C)
- ④ Screw (D)
- ⑤ Idler
- ⑥ Machine socket unit connector (primary circuit)
- ⑦ Switching power supply unit